

MAC 200

STRUCTURAL
STANDING SEAM
METAL ROOF SYSTEM

Trusted | Tested | Tough



kloeckner metals

91-104 Kalaeloa Blvd, Kapolei, Hawaii 96707

Phone (808) 682-3000

Fax (808) 682-3636

Neighbor Islands (800) 352-3920

www.kloecknermetals.com



MAC 200 STANDING SEAM METAL ROOF SYSTEM

MAC 200 FEATURES

PRODUCT DATA

- Kloeckner Metals **MAC 200** is a structural standing seam metal roof system. The panel has 2" high standing seams and is mechanically seamed over two-piece, concealed clips. Rated for extreme uplift pressure resistance
- Recommended slopes are ¼:12 and greater.
- It may be installed over open purlins with a maximum span of 5', on plywood deck, or on rigid foam insulation over steel deck.
- Mechanical seam increases uplift resistance.
- Eight standard stocking colors
- Smooth or ribbed pan surface.
- Optional automatically applied, hot melt seam sealant.
- UL 580 Class 90 Uplift Rating.
- ASTM E 1592 Tested
- ASTM E 1646 Tested
- ASTM E 1680 Tested

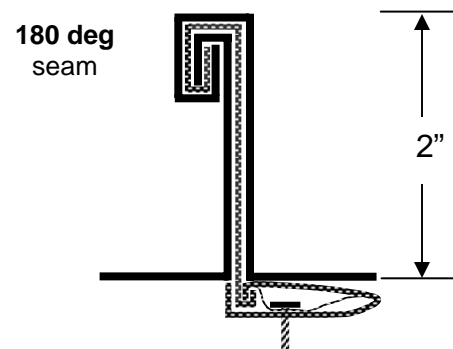
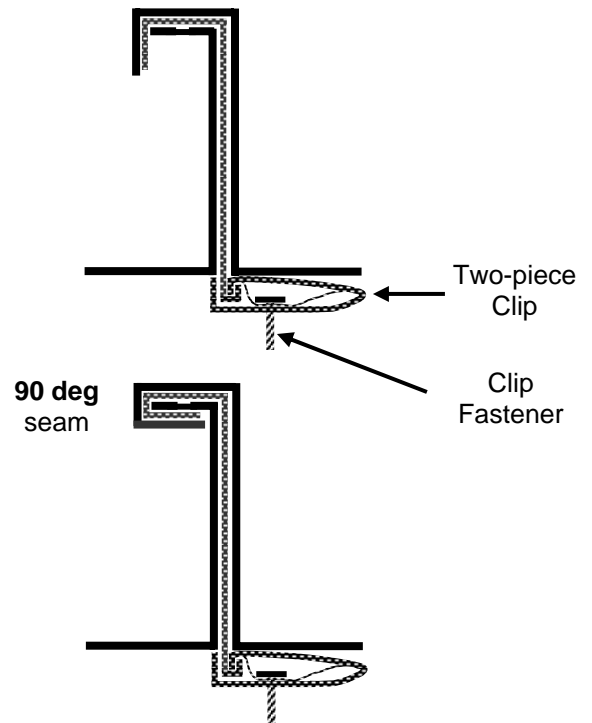
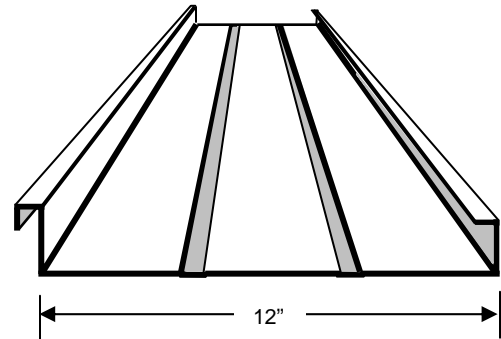

MAC 200 STANDING SEAM METAL ROOF SYSTEM

ARCHITECT / ENGINEER INFORMATION

1. **MAC 200** is a mechanically seamed, integral standing seam metal roof system, available in widths: 18", 16", and 12".
2. The minimum recommended slope is 1:12. For slopes less than 1:12, call Kloeckner Metals.
3. **MAC 200** is a UL90 rated, structural roofing panel. This panel can be installed directly over purlins or bar joists. It does not require a solid substructure for support.
4. Narrower widths, heavier gauges, and embossing minimize oil canning. Industry standard is 12" wide, 24 gauge. Oil canning is not a cause for rejection.
5. Substructure must be on an even plane (1/4" tolerance) from eave to ridge to avoid panel distortion (oil canning).
6. All panels require end sealant at eave and valley conditions. However, for illustration purposes, this sealant is not shown on all drawings.
7. The information in this manual is believed to be correct and accurate. It should not be used for any specific application without being reviewed by a registered professional engineer.
8. Avoid restricting thermal expansion and contraction of the **MAC 200** panels (i.e. do not attach panels to the substrate at both the eave and ridge).
9. **MAC 200** panels are not designed to be work platforms. Avoid any unnecessary foot traffic on **MAC 200** panels. If foot traffic is required, protect the roof panels by using some type of roof pad, temporary deck, or walkway.
10. When installing **MAC 200** panels over open framing with blanket insulation: (A) install insulation parallel to purlins or joists, or (B) install insulation across purlins or joists and compress it with pinch bars or hat channels.
11. A vapor retarder may be necessary to protect roofing components when high interior humidity is a factor. An architect or engineer should determine the need for a vapor retarder, as well as the type, placement and location. The following are examples of conditions that may require a vapor retarder: (A) Project where outside temperatures below 40 deg. F are anticipated where average interior relative humidity of 45% or greater is expected; (B) Building usages with high humidity interiors, such as indoor swimming pools, textile manufacturing operations, food, paper or other wet-process industrial plants; (C) Construction elements that may release moisture after the roof is installed, such as interior concrete and masonry, plaster finishes and fuel burning heaters.

CAUTION

Diaphragm capabilities and purlin stability are not provided by Kloeckner Metals MAC 200 roof system. Therefore, other bracing may be required to conform to A.I.S.I or A.I.S.C. specifications

MAC 200 STANDING SEAM METAL ROOF SYSTEM

PREPARATORY REQUIREMENTS

1. The eave purlin must be in the same plane as the roof purlins.
2. Rake angles, hip and valley covers must be installed on top of the purlins prior to installing the **MAC 200** panels. Gauge of the material to be determined by the project engineer.
3. The building must be squared according to accepted building practices.
4. It is critical that the purlins or bar joists at the ridge and end laps be located exactly as detailed and they are straight from rafter to rafter. Any mislocation or bowing of these members can cause the fasteners at the ridge or end laps to foul as the panels expand and contract.
5. Peak purlin spacing:
 - Fixed ridge: 10" (5" from center line of ridge to web of purlin.)
 - Floating ridge: 18" (9" from center line of ridge to web of purlin.)
6. Kloeckner Metals can furnish **MAC 200** roof panels in 12", 16" and 18" widths.
7. However, for the purposes of this manual, we have assumed that the roof panels will be 12" wide.

CAUTION

Application and design details are for illustration purposes only, and may not be appropriate for all environmental conditions or building designs. Projects should be engineered to conform to applicable codes, regulations, and accepted industry practices.

CAUTION

Diaphragm capabilities and purlin stability are not provided by Kloeckner Metals MAC 200 roof system. Therefore, other bracing may be required to conform to A.I.S.C. or A.I.S.I. specifications.

MAC 200 STANDING SEAM METAL ROOF SYSTEM

ALLOWABLE LOAD TABLES

ALLOWABLE LIVE LOAD (PSF)

Panel Gauge	Panel Width	# of Equal Spans	SPAN (FEET)							
			2.0	2.5	3.0	3.5	4.0	4.5	5.0	5.5
24 Gauge Steel	12" Inch	1	348	278	231	198	154	121	98	81
		2	299	239	188	139	107	85	69	57
		3	327	262	217	161	124	98	80	66
22 Gauge Steel	12" Inch	1	501	401	333	265	202	159	129	106
		2	418	335	264	195	150	119	96	79
		3	458	366	305	226	174	138	112	92

Notes:

1. All calculations for panel properties have been made in accordance with the 1996 edition of "Specifications for Cold-Formed Steel Design Manual" published by the American Iron and Steel Institute.
2. Values for 3 or more spans are based on 4 equal spans.
3. These load capacities are for the panel itself. Frames, purlins, clips, fasteners, and all supports must be designed to resist load imposed by the panel.
4. Materials:
FY= 40 KSI for steel panels.
5. All loads are in PSF.
6. Minimum panel support bearing length = 3.00 in.
7. Loads shown are limited by L/180 deflection.

MAC 200 STANDING SEAM METAL ROOF SYSTEM

ALLOWABLE LOAD TABLES

ALLOWABLE UPLIFT LOAD (PSF)

Panel Gauge	Panel Width	# of Equal Spans	SPAN (FEET)							
			2.0	2.5	3.0	3.5	4.0	4.5	5.0	5.5
24 Gauge Steel	12" Inch	1	466	373	265	196	150	119	97	80
		2	400	320	267	229	198	159	130	108
		3	437	350	292	250	219	183	150	125
22 Gauge Steel	12" Inch	1	671	530	369	272	209	165	134	111
		2	559	447	373	320	264	211	172	143
		3	611	489	408	349	305	244	199	166

Notes:

1. All calculations for panel properties have been made in accordance with the 1996 edition of "Specifications for Cold-Formed Steel Design Manual" published by the American Iron and Steel Institute.
2. Values for 3 or more spans are based on 4 equal spans.
3. These load capacities are for the panel itself. Frames, purlins, clips, fasteners, and all supports must be designed to resist load imposed by the panel.
4. Materials: FY= 50 KSI for steel panels.
5. All loads are in PSF.
6. Minimum panel support bearing length = 3.00 in.
7. Loads shown are limited by L/180 deflection.
8. Above capacities have been increased by 33-1/3% as per AISI Sec. A4.4.
9. **THESE UPLIFT LOAD TABLES ARE FOR PANEL CAPACITY ONLY. FULL SCALE TESTS SUCH AS ASTM E-1592 MUST BE CONDUCTED TO DETERMINE THE FULL CAPACITY OF THE PANEL SYSTEM, INCLUDING CLIPS AND INTERLOCKING SYSTEM.**

MAC 200 STANDING SEAM METAL ROOF SYSTEM

NEGATIVE DESIGN LOADS (WITH 180 DEG. SEAM)

SPAN (FT)	ULTIMATE TEST LOAD (PSF)	DESIGN LOAD (PSF)
2	262.3	174.4
2.5	-	157.0
3	-	139.6
3.5	-	122.2
4	-	104.8
4.5	-	87.4
5	105.3	70.0

Notes:

1. The above loads were derived from uplift tests done in accordance with ASTM E 1592-01 (see Farabaugh Engineering and Testing, Inc. Test Report No. T214-01 for specific test data)
2. Design values are interpolated from tests performed at spans of 2'-0" and 5'-0" only.
3. Design load contains a 2.0 factor of safety and a 33% increase due to wind per AISI 96, Sec. A4.4.
4. Materials:
FY= 50 KSI for steel panels.
5. All loads are in PSF.
6. Minimum panel support bearing length = 3.00 in.

MAC 200 STANDING SEAM METAL ROOF SYSTEM

AIR LEAKAGE TEST

Per ASTM E 1680-95

Test Specimen	Static Pressure Differential (PSF)	Total Air Leakage (CFM)	Air Infiltration Rate (CFM/LF)	Air Infiltration Rate (CFM/SF)
MAC 200 SSMRS 24 ga 18" wide	+1.57	0.1	0.002	0.001
	-1.57	0.7	0.013	0.009
	+6.24	0.5	0.010	0.006
	-6.24	0.8	0.015	0.010
	+12.00	0.8	0.015	0.010
	-12.00	1.0	0.019	0.013

WATER PENETRATION TEST

Per ASTM E 1646-95

Test Specimen	Static Pressure Differential (PSF)	Rate	Test Duration	Water Infiltration
MAC 200 SSMRS 24 ga 18" wide	6.24	5 Gal/hr./sf	15 min	None
	12.0	5 Gal/hr/sf	15 min	None
	20.0	5 Gal/hr/sf	15 min	None

MAC 200 STANDING SEAM METAL ROOF SYSTEM

THERMAL MOVEMENT

Maximum Roof Panel Length

Maximum length of roof panel is 150'

Two-piece clip offers unimpeded thermal movement and does not restrict length of multiple panel runs.

Panel Fixing Information

Standing seam roof panels must be fixed at any one of the following places: Eave, ridge, hip, or an intermediate location for longer length panels. (Note structural requirement for reinforcing supports at fixing lines.)

Steel panels 30'-0" long or less may be fixed at eave and ridge, peak, or hip. Fixing of the eave is preferred when gutters are subject to high wind loads.

See graph (Fig. 1) for steel thermal movement for temperature changes from 50 deg F to 250 deg F.

Total Thermal Movement (in.)

2-1/4"
2"
1-3/4"
1-1/2"
1-1/4"
1"
3/4"
1/2"
1/4"

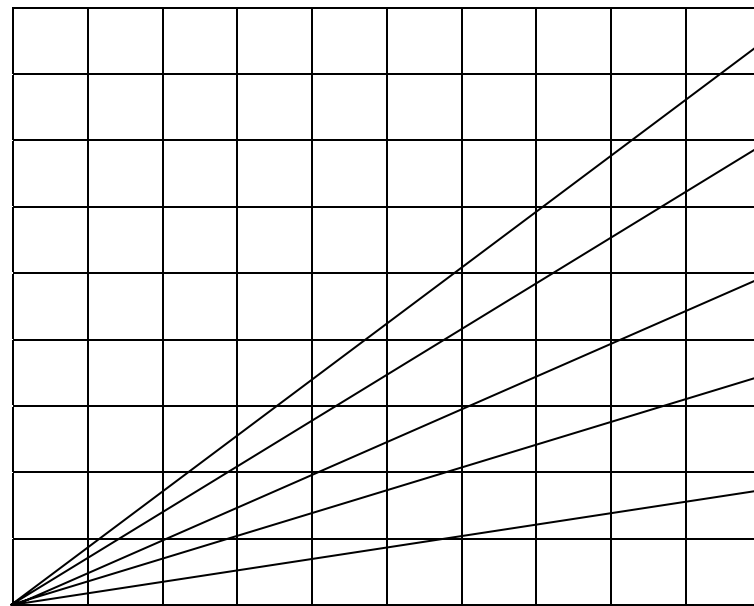

Temperature Differential (deg F)

250 deg F
200 deg F
150 deg F
100 deg F
50 deg F

10' 20' 30' 40' 50' 60' 70' 80' 90' 100'
Distance From a Fixed Point (ft)

FIG. 1 – LINEAR THERMAL EXPANSION FOR STEEL PANELS